

PCBLAYOUT

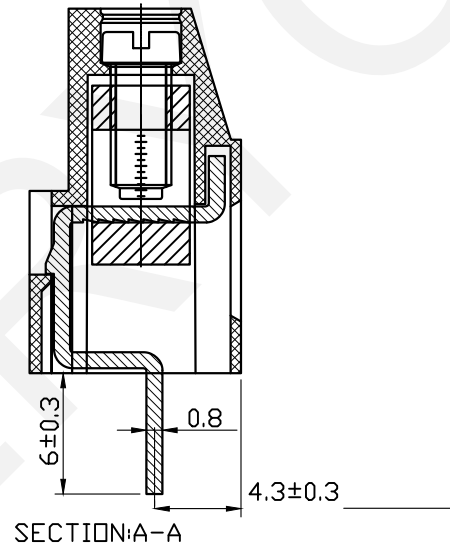
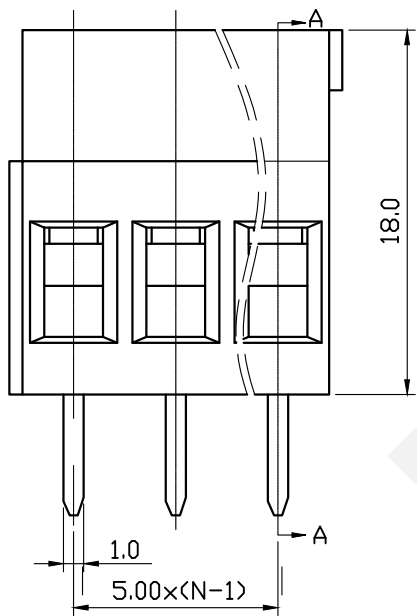

Material

Housing:PA66,UL94V-0
 Clamp:Brass, Ni plated
 Pin header:Brass, Tin plated
 Screw:M3.0, steel Zinc plated
 Electrical

Rated voltage:300V
 Rated current:20A
 Contact Resistance: 20mΩ

Insulation resistance: 500MΩ/DC500V
 Withstand voltage: AC2000V/1min
 Wire Range:26~12AWG 2.5mm²

Mechanical

Temp. Range:-40℃~+105℃
 Strip length:6~7mm
 Torque:0.5Nm (4.5Lb.in)

Order Information

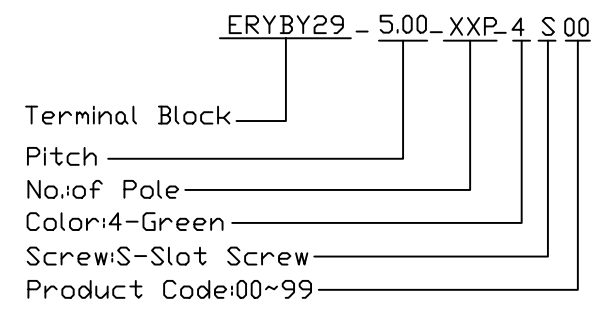

NINGBO ERYCO ELECTRONIC CO.,LTD

UNITS:mm	SHEET SIZE: A4			SCALE:---	DRWN BY PAN
0~3	3~18	18~50	50~120	CHK'D BY FENG	
±0.12	±0.15	±0.3	±0.5	APPR BY ZHAN	

Screw Conn Term Block 5.00mm	
THIRD ANGLE PROJECTION	ERYBY29-5.00-XXP-4S

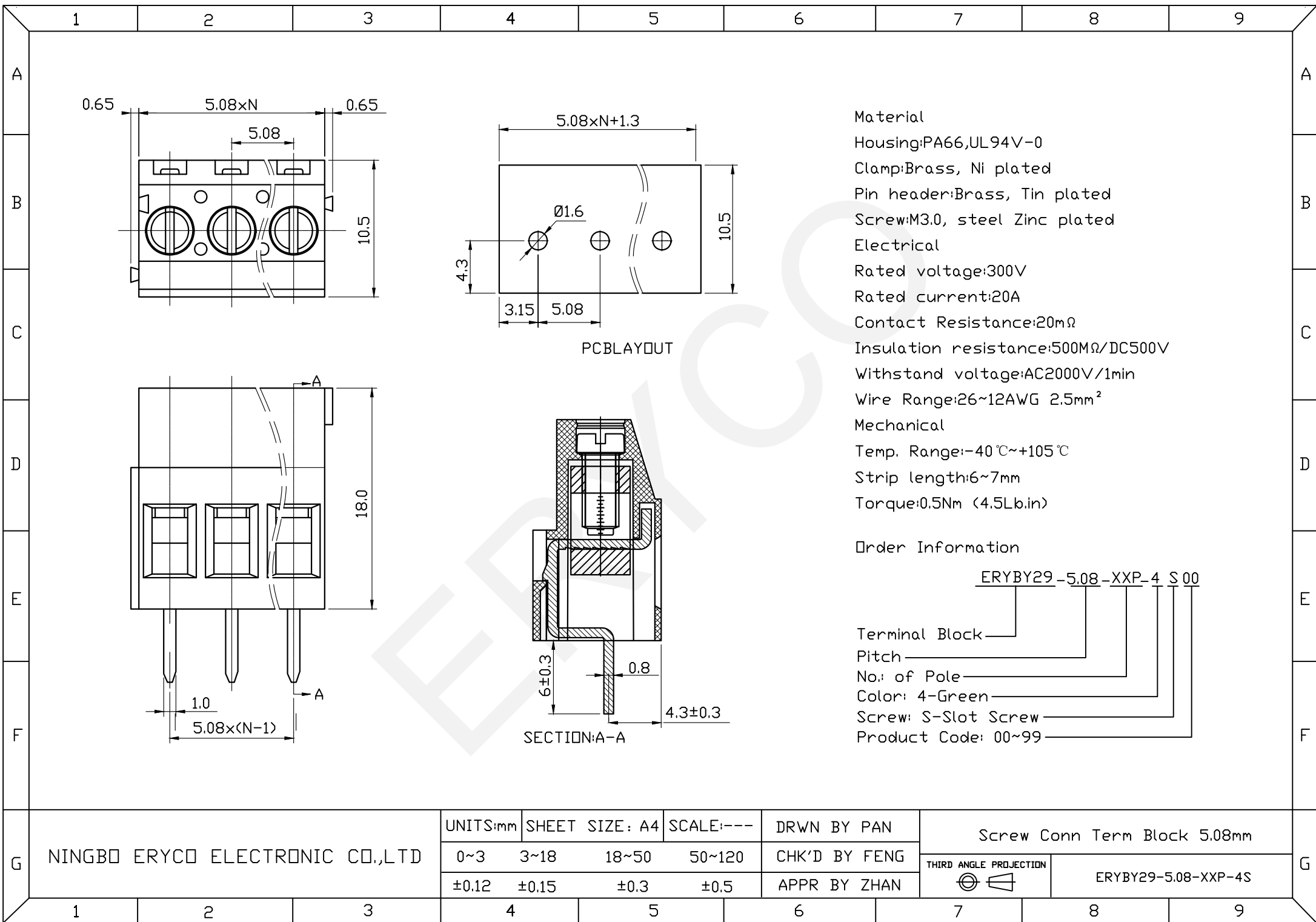

NINGBO ERYCO ELECTRONIC CO.,LTD

UNITS:mm	SHEET SIZE: A4			SCALE:---	DRWN BY PAN
0~3	3~18	18~50	50~120	CHK'D BY FENG	
± 0.12	± 0.15	± 0.3	± 0.5	APPR BY ZHAN	

Screw Conn Term Block 5.08mm	
THIRD ANGLE PROJECTION	ERYBY29-5.08-XXP-4S